

Container Crane Modernization & Retrofits

Maximize Your Investment Value



metals

cranes

paper

cement

oil & gas

mining

utilities

rubber &
plastics

One company. A world of solutions.

Why Modernize?

TMEIC GE Automation Systems has been a leading supplier of crane control systems for over 60 years.

We have the largest installed base of legacy and new crane control and automation systems of any controls manufacturer in the world.

TMEIC GE Experience:

- Container cranes
(Quay or ship to shore cranes)
- Rubber tired yard cranes
- Rail mounted yard cranes
- Bucket cranes

Look at what we have to offer!



There have been only two options for equipment improvement:

- Buy a new crane?
- Modernize your present crane but incur a heavy penalty of lost crane time while the modernization is taking place?

Container Terminal Operators are faced with many diverse equipment issues:

- Equipment Obsolescence
- Performance Limitations
- Productivity Enhancements
- Downtime Reduction
- Safety Enhancements
- Operating Cost Reduction

TMEIC GE Automation Systems now has better, far more cost effective options – cost effective modernization and retrofit packages which will:

- Increase throughput
- Increase uptime by improving reliability
- Reduce repair time and costs
- Improve response time
- Improve crane control
- Build in versatility for future technology

These issues and modernization options are discussed on the opposite page.

Solutions to Equipment Issues



Equipment Obsolescence

Bringing old cranes new life, making spare parts available, and reducing technical support requirements by:

- Drives retrofits
- Controls retrofits
- Motor refurbishment
- MG set refurbishment



Downtime Reduction

Improving crane availability and lowering maintenance cost by installing:

- Enhanced diagnostics
- Remote crane management system (RCMS)
- Automatic crane protection
- Drive control upgrade
- Drive upgrade



Operating Cost Reduction

Reducing wasted energy, power quality penalties, and reactive power demand charges by installing:

- Power factor regulation
- Harmonic filtering
- Regenerative load absorption regulation
- Power system conversions



Productivity Enhancements

Taking advantage of the latest crane automation to improve crane productivity and flow of product by:

- Crane load sway control
- Crane automation features
- Chassis & straddle carrier alignment systems
- Yard management systems
- Enhanced diagnostics
- Crane management systems
- Closed circuit TV
- Container ID recognition systems



Safety Enhancements

Improving working conditions, reducing lost time, and meeting regulatory body requirements using:

- Crane to crane anti-collision
- Crane to ship anti-collision
- Automatic steering
- Straddle carrier detection
- Automatic smart slowdowns over dock and below vessel deck
- Fall arrest systems



Physical and Performance Limitations

Overcoming outreach, lift height and performance limitations to achieve higher speeds and lifting capacities by:

- Crane lift extension
- Boom girder extension
- Drive upgrades
- Motor upgrades
- Control upgrades

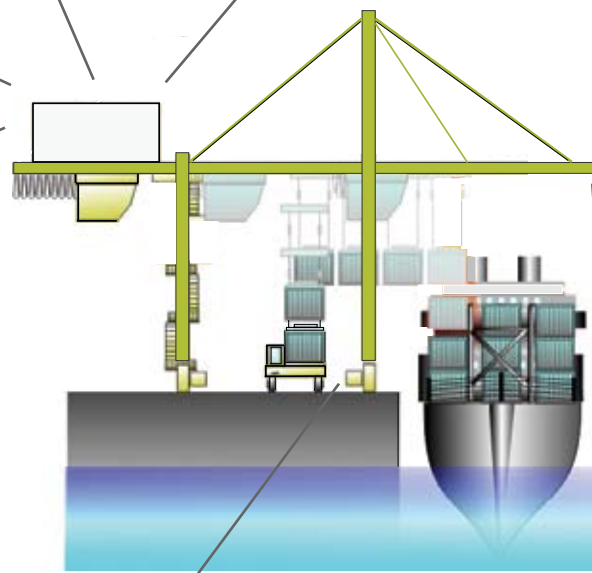

Drives and Controls

The list below contains the vintage GE Drive Systems in use today along with a brief summary of the options for drive and control system upgrades.

The legacy DC drive can be replaced with the new TM-DC drive or the control and communication boards can be replaced using the TM-DC DFE (Digital Front End).

When upgrading DC drive systems, establish whether the existing DC motors or generators are suitable for operation on 6-pulse, SCR power conversion technology by consulting with the original drive system and DC motor or generator manufacturer. It may be necessary to replace the motors or generators; in other situations, the DC generators or motors may only require re-conditioning, or upgrading of the armature banding.

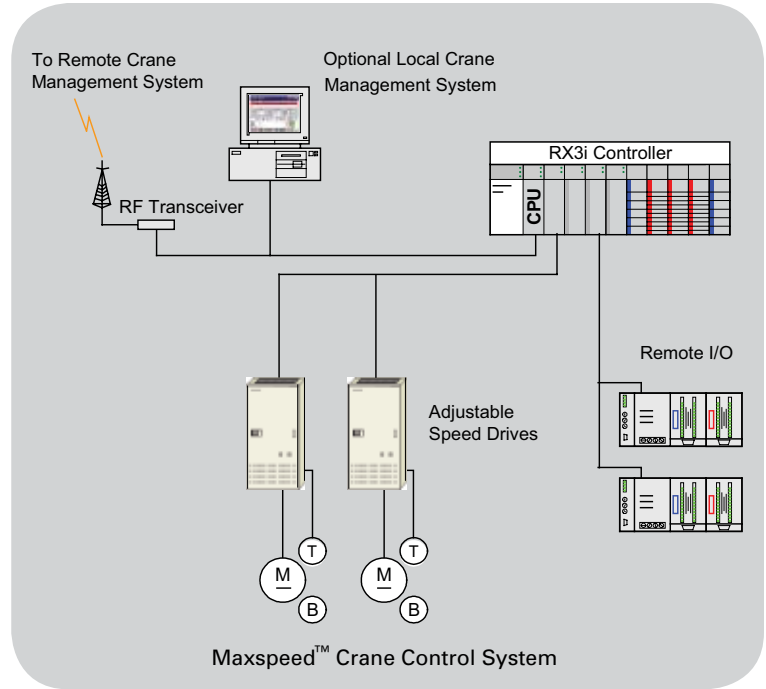

Modernize the crane control system by replacing hardwired relay logic systems or obsolete PLC-based systems with a state of the art PLC-based Maxspeed control system. Optionally, remote I/O stations may be added to enhance local troubleshooting and monitoring, e.g. waterside and landside gantry I/O stations, boom operator stations, operator's cabin/trolley I/O stations, etc.

Drives and Controls Retrofits

Type of Control System	Logic Type	Drive Control	Drive Modernization Path	PLC Modernization
M-G Set	Hardwired	S21 Regulator Valutrol® DFM 300	TMdrive™ -DC GF	90-30 PLC RX3i with VersaMax I/O
Static Power Supply	Hardwired	S21 Regulator	TM-DC	90-30 PLC RX3i PLC with VersaMax® I/O
	Hardwired Series 1 PLC Series 6 PLC IOS 90-70 PLC	Valutrol DC300 DC2000	TM-DC or TM-DC DFE	90-30 PLC RX3i PLC with VersaMax I/O

Installing Communications Brings Benefits

Operations can be significantly enhanced by integrating and connecting the tasks and equipment involved in moving containers. High-speed communications are employed using fiber optics, or wireless, or both as shown in the diagram. The recommended modernization work includes the following:



Installing Optical Character Recognition (OCR) imaging technology to:

- Read container ID numbers
- Transmit to yard office
- Assist in positioning container chassis, carts, and carriers under the cranes



Installing Communications between the crane control system and the yard management system to provide information such as:

- Container size
- Container pick up and drop off coordinates
- Twistlock status
- Twistlock commands
- Automated move job orders



Installing a Local Crane Management System (LCMS) on the cranes to provide:

- Advanced machinery diagnostics
- Advanced trouble-shooting aids
- Customized graphically animated monitoring aids
- Productivity reports
- Preventative maintenance screens
- Alarm and event logs



Installing a Remote Crane Management System (RCMS) in the yard office to provide:

- Monitoring of multiple cranes in the terminal
- Centralized machinery diagnostics and trouble-shooting aids
- Terminal-wide productivity reports
- Preventative maintenance screens
- Alarm and event logs

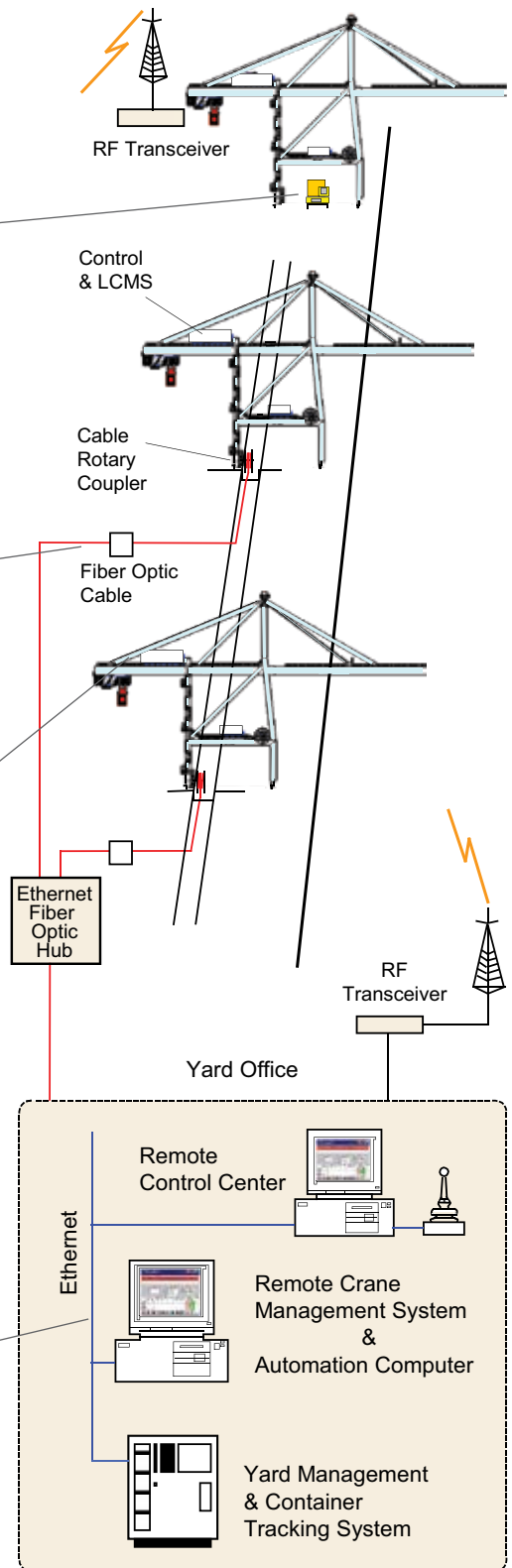

Power Quality

Low Power Factor



Low crane power factor results primarily from inductive loads such as transformers, induction motors, and DC drives. Low power factor can cause utilities to increase their billings through:

- Power factor penalties
- Reactive power demand charges

Installing a Crane Factor+™ regulation system as illustrated here can provide significant operating cost savings.

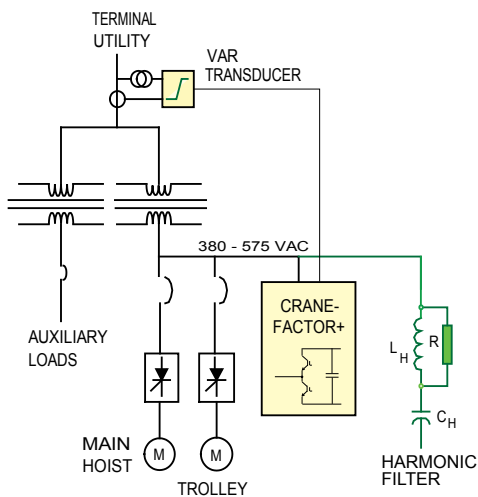

Voltage Regulation

In the case of a soft power system, install a Crane Factor+ system using a TMdrive-P10 pulse width modulated converter:

- The active IGBT converter regulates the AC line voltage at the crane drive terminals and regenerates power back to the supply
- The large capacitors in the TMdrive-P10 store energy for voltage regulation purposes
- Can provide a temporary solution for low voltage conditions during terminal expansion

Power Factor Regulation

A Crane Factor+ system is easy to retrofit on any system, regardless of supplier. The CF+ system:

- Regulates the power factor as a function of the reactive power demand using a TMdrive Pulse Width Modulated IGBT converter
- Extends the life of the crane electrical equipment
- Reduces the probability of power conversion failures
- Will not interfere with the existing terminal and utility distribution system
- Provides significant energy cost savings
- Improves voltage stability

Harmonic Filtering

Install a harmonic filter consisting of a tuned circuit with inductance, capacitance, and resistance. The filter circuit:

- Presents low impedance at the selected filter frequency
- Mitigates harmonic currents and reduces distortion caused by the adjustable speed drives
- Protects against voltage distortion that can effect the performance of different loads and other users on the utility
- Can be designed to comply with IEEE 519 Standard
- Reduces the opportunity for resonance in the distribution system which can cause overheating and trips
- Provides additional VARs from the capacitance

Example of Power Quality Improvements

One crane, motoring, one minute demand.

	MW	MVA	P.F.
No Correction applied	1.34	1.90	0.705
Power Factor Correction only	1.34	1.44	0.926
Power Factor Correction & Harmonic Filtering	1.34	1.35	0.994

Regenerative Load Absorption Control

Older cranes rely on contactors to switch regenerative load currents to resistor banks to dissipate the energy. Due to the extreme duty, contactor tips must be replaced frequently at high parts cost and increased labor cost.

This switching is best done with solid state devices such as SCRs. The RC2000 regenerative load absorption controller can be retrofitted to any existing diesel engine powered container crane. The RC2000 controller:

- Avoids high contactor maintenance cost
- Provides greater reliability
- Reduces impact loading on the engine and alternator
- Increases crane availability
- Reduces engine fuel cost by 5-10%

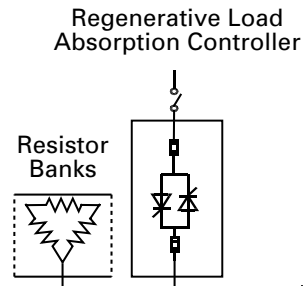

RC2000 Installation in Crane Machinery House



Diesel Generator to Utility Power Conversions

Power houses can be supplied that incorporate the following:

- Power quality equipment
- Indoor or outdoor construction
- Structural bases suitable for mounting on the portal beam, sillbeam, or trolley girders.

The power house illustrated here has:

- 6.6 kV disconnect load break
- 6.6 kV to 480 V three phase transformer
- Switchover between utility power and diesel generator power, key interlocked to prevent mis-operation
- Crane Factor+ VAR compensator system for use when utility power is on.

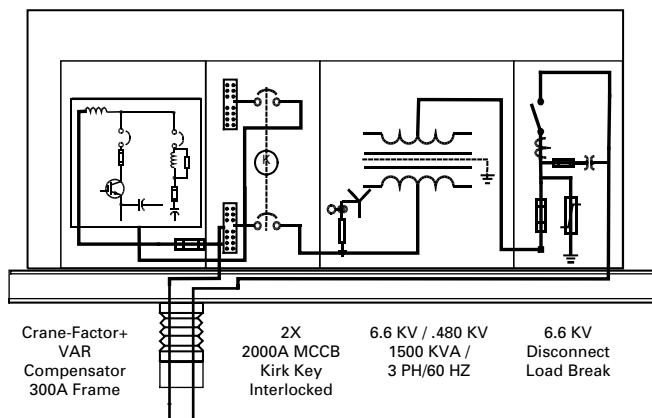

Power House Assembly



Complete power house designs are available to facilitate the conversion of diesel engine powered cranes to utility power. Conversions may involve either:

- The addition of medium voltage cable reels on the crane
- The installation of underground collector bay systems

Often transfer schemes and cable reel control modules are included that allow the existing diesel engine – alternator systems to remain in the system as a backup power source in the event the utility power is not available.

Advantages include:

- Reduced operating costs by eliminating fuel and engine maintenance cost
- Reduced pollution
- Increased reliability and availability

Container Crane Modernization & Retrofits Contacts

TMEIC GE is a joint venture between Toshiba, Mitsubishi-Electric, and General Electric in the industrial system drives business. The adjacent diagram shows how the companies came together starting in 2000, to create an organization of 2200 people with annual sales in excess of \$1B.

It is built upon the combined and proud heritage of these great companies. TMEIC GE focuses on delivering customer success, every project, every time.

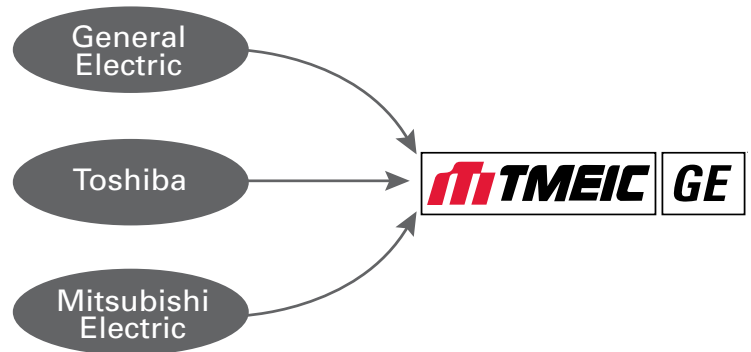

Your Modernization and Retrofit Contacts:

TM GE Automation Systems, USA

Office: 1501 Roanoke Blvd. Salem VA 24153 USA
Mailing: 2060 Cook Drive, Salem, VA 24153 USA
TEL: +1-540-387-5741; FAX: +1-540-387-7060

Toshiba Mitsubishi - Electric Industrial Systems (Shanghai) Corp. Shanghai Liaison Office

2603 Shanghaimart Tower
2299 Yan An Road (W)
Shanghai, China 200336
TEL: (86-21) 62360588; FAX: (86-21) 62360599

Toshiba Mitsubishi-Electric Industrial Systems (Beijing) Corp.

703 Building A, Technology Fortune Center,
No. 8 Xue Qing Road,
Haidian District, Beijing 100085, P. R. China
TEL: +86 10 8273-7788; FAX: +86 10 8273-7786

TM Drive Systems Company Ltd.

1015 Nan Fung commercial Centre,
19 Lam Lok St.
Kowloon Bay, Hong Kong.
TEL: +852-2243-3321; FAX: +852-2795-2250

Toshiba Mitsubishi-Electric Industrial Systems Corporation

Mita 43, MT Bldg.
13-16 Mita 3 chome, Minato-ku Tokyo
108-0073 Japan
TEL: +81-3-5444-3828; FAX: +81-3-5444-3820
www.tmeic.co.jp

Crane Factor+ is a trademark of General Electric Company.
TMdrive is a trademark of TMEIC Corporation.
Maxspeed is a trademark of TMEIC Corporation.
Valutrol is a registered trademark of General Electric Company.
VersaMax is a registered trademark of GE Fanuc Automation North America, Inc.

All other products mentioned are registered trademarks and/or trademarks of their respective companies. TM GE in no way endorses or is affiliated with any products not owned and sold by TM GE and its related entities. All specifications in this document are subject to change without notice.